



Agil

MANIGLIE AD INCASSO PER
CHIUSURE LATERALI
BUILT-IN HANDLES FOR
SIDE CLOSING

 **LAVAAL**
international

accessori per serramenti / door and window frame fittings and accessories

NEL SUO NOME LA SUA PERSONALITÀ: FORTE E POLIEDRICA. ITS NAME DETERMINES ITS PERSONALITY: STRONG AND VERSATILE.

Agil è la nuovissima serie di maniglie ad incasso per chiusure laterali nei serramenti scorrevoli. Le maniglie si applicano senza viti in vista con un sistema semplice e veloce di montaggio a scatto.

Agil is the newest series of built-in handles for the side closing of sliding doors. The handles are assembled without visible screws with a quick and simple snap assembly system.

AGIL È PRODOTTA
INTERAMENTE IN ITALIA.
AGIL IS ENTIRELY
MANUFACTURED IN ITALY.

I PUNTI DI FORZA

STRENGTHS

1

APPLICAZIONI INFINITE
Innumerevoli profili scorrevoli troveranno applicazione con AGIL.

MANY SUITABILITY APPLICATIONS
Agil can be applied on many sliding profiles.

2

MONTAGGIO RAPIDO E SEMPLICE
Uno scatto ed è fatta, rapidità e semplicità vi sorprenderanno.

QUICK AND EASY
One click and it is done, the speed and simply way to fix it will surprise you.

3

GRANDE ADATTABILITÀ
Linee arrotondate o design essenziale?
Ogni profilo avrà la sua AGIL.

GREAT AND LARGE SUITABILITY
Is it for Rounded or simple design?
Each profile will have its AGIL.

4

100% DI SICUREZZA
Sistema antieffrazione e multichiusure completano un prodotto perfetto.

100% SAFETY
Anti-theft system and multi locking points can complete this perfect product.



1. Gancio inox regolabile.
1. Adjustable stainless steel hook.

6. Tappo copri grano di fissaggio.
6. Fixing grub screw cap cover.

3. Superficie rigata per aumentare la presa.
3. Ribbed surface for better grip.

2. Supporto del gancio rinforzato.
2. Reinforced holder hook

5. Cilindro unica cifratura
5. Cylinder lock with own key.

4. Molla in dotazione per il ritorno automatico.
4. Supplied spring for automatic return.

5. Perno di rinforzo.
5. Reinforcement pin.

7. Sistema rapido e semplice di fissaggio al profilo senza utilizzo di viti.
7. Quick and simple profile fixing system without the use of screws.

4. Scatto di posizionamento maniglia aperto/chiuso con sistema di antieffrazione.

4. Open/close handle snap positioning with burglar-proof system.

8. Disponibili nei vari colori con o senza chiave di sicurezza.
8. It is available in various colours, with or without a safety key.

5. Indicatore rosso/verde di chiusura/apertura e linea arrotondata.
5. Red/green open/close indicator and rounded line.

9. Tutte le maniglie sono state collaudate secondo la normativa UNI EN 13126 ottenendo risultati positivi per durabilità, resistenza, sicurezza e funzionalità.
9. The only handles have been tested according to UNI EN 13126 standards obtaining positive results in durability, resistance, safety and functionality.

LA QUALITÀ? PROGETTATA, CONTROLLATA, PROVATA.

CERTIFICAZIONE . Lavaal adotta procedure interne di controllo sul processo produttivo e sui fornitori, in accordo con il Sistema Qualità certificato UNI EN ISO 9001:2008.

CONTROLLI . L'elevato standard qualitativo è assicurato dai controlli in accettazione e sulle linee di prodotto. Tutti i materiali in ingresso vengono sottoposti a controlli dimensionali a campione ed a prove durometriche, per monitorare e verificare la durezza dei materiali.

PROVE DI LABORATORIO . Il laboratorio testa i prodotti in fase di progettazione e prototipazione, in linea con le normative europee UNI EN ISO 13126:1+19. I test finali si svolgono presso gli Istituti Europei più prestigiosi.

WHAT ABOUT LAVAAL QUALITY? DESIGNED, CHECKED AND TESTED.

CERTIFICATION . Lavaal applies internal control procedures on the production process and suppliers, in accordance with the Quality System certified UNI EN ISO 9001: 2008.

CHECKING . The high quality standard is guaranteed by the checking at the materials reception acceptance and during checking on production lines. All incoming materials are checked through dimensional sampling and hardness values testing to monitor and verify the raw materials.

LABORATORY TESTS . The laboratory tests products during design and prototyping are going to be effected according with European standards UNI EN ISO 13126: 1+19. The final tests are held at the most prestigious European Institutes.



MANIGLIA AD INCASSO PER CHIUSURE LATERALI.

BUILT-IN HANDLES FOR SIDE CLOSING

Gli ingombri contenuti della maniglia, permettono il montaggio anche su profili estremamente piccoli e il sistema rapido e semplice di fissaggio ne permette l'applicazione su lavorazioni rettangolari o rotonde.

La maniglia AgilMini viene confezionata e fornita con combinazione ritorno automatico.

Il serraggio del grano nella speciale seghettatura del gancio assicura la stabilità dello stesso nel tempo.

The small overall dimensions of the handle also allow it to be assembled on extremely small profiles, and the quick and easy assembly allows application on rectangular or round processes. AgilMini handles are packaged and supplied with an automatic return combination.

Tightening the grub screw in the special serrated edge of the hook guarantees its stability over time.



AgilMini

ART. 23100.00.00

MANIGLIA AD INCASSO PER CHIUSURE LATERALI
BUILT-IN HANDLES FOR SIDE CLOSING

20 PEZZI / 20 PIECES

LAVORAZIONE PROFILO QUOTA X VARIABILE
IN FUNZIONE DEL SISTEMA
PROFILE PROCESSING X DIMENSION VARIES
IN RELATION TO THE SYSTEM

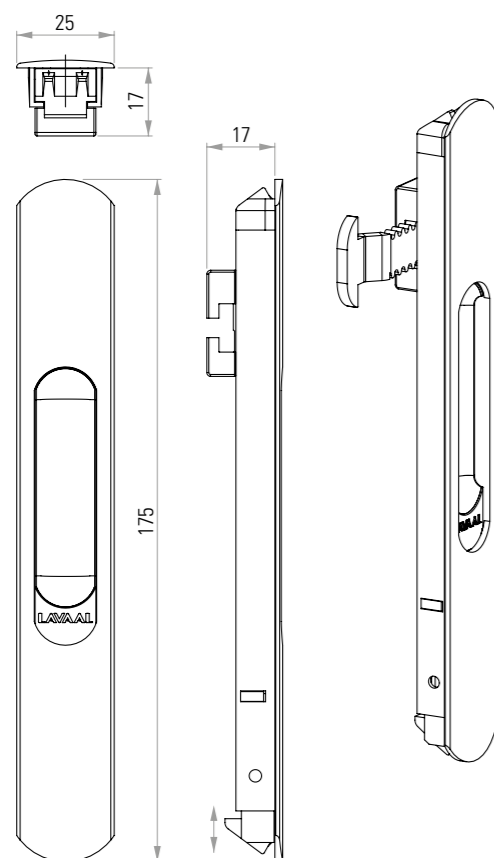
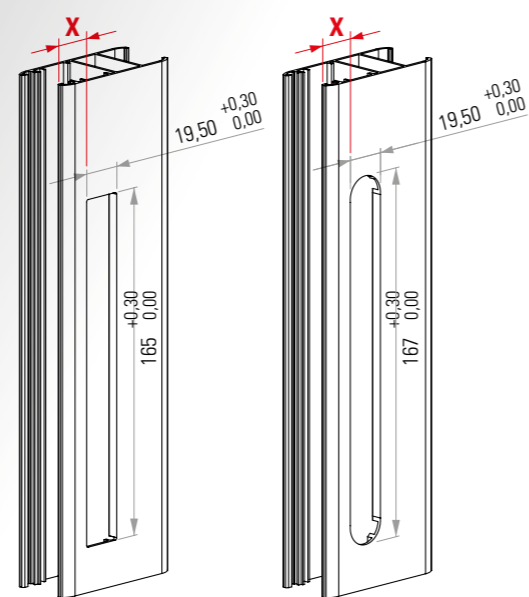

1. Gancio di chiusura regolabile in acciaio inox.
1. Adjustable stainless steel hook.

2. Supporto del gancio rinforzato.
2. Reinforced holder hook

4. Superficie rigata per aumentare la presa.
4. Ribbed surface for better grip.

5. Solo ritorno automatico.
5. Only automatic return.

6. Perno di rinforzo.
6. Reinforcement pin.

3. Interamente MADE IN ITALY.
3. Entirely MADE IN ITALY.

7. Sistema rapido e semplice di fissaggio al profilo senza utilizzo di viti.
7. Quick and simple profile fixing system without the use of screws.



TUTTE LE MANIGLIE SONO STATE COLLAUDATE SECONDO LA NORMATIVA UNI EN 13126-19: 2011 OTTENENDO RISULTATI POSITIVI PER DURABILITÀ, RESISTENZA, SICUREZZA E FUNZIONALITÀ.

THE ONLY HANDLES HAVE BEEN TESTED ACCORDING TO UNI EN 13126-19:2011 STANDARDS OBTAINING POSITIVE RESULTS IN DURABILITY, RESISTANCE, SAFETY AND FUNCTIONALITY.

FISSAGGIO DEL GANCIO DI CHIUSURA
FIXING THE HOOK CLOSURE

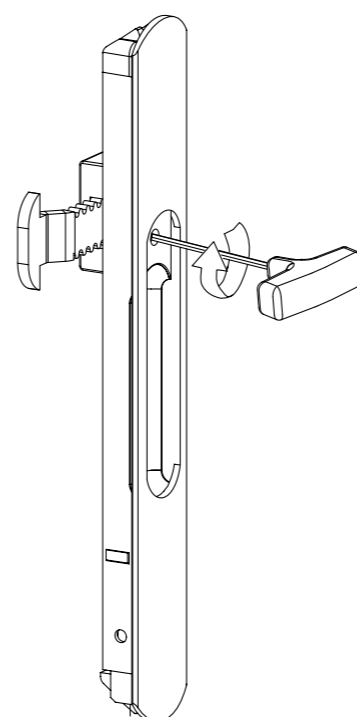

SISTEMA DI FISSAGGIO
FIXING SYSTEM

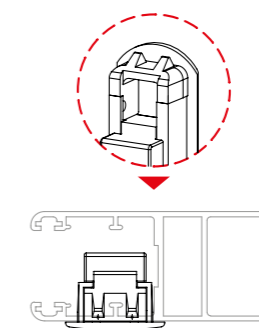

Si fissa al profilo con una leggera pressione.
It can be fixed to the profile with light pressure.

1. Appoggiare al profilo.
Just Put it over the profile.

COMBINAZIONE CON RITORNO AUTOMATICO
COMBINATION WITH AUTOMATIC RETURN

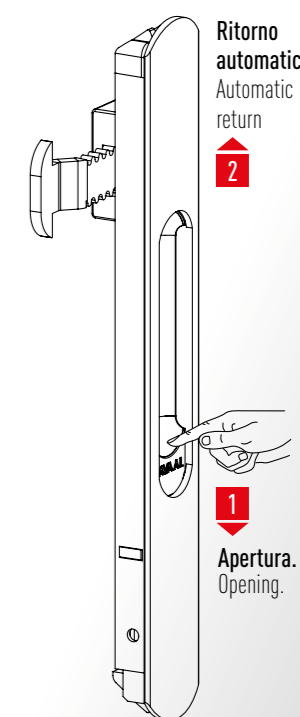

Ritorno automatico
Automatic return

2

1. Apertura.
Opening.

MANIGLIA AD INCASSO PER CHIUSURE LATERALI.

BUILT-IN HANDLES FOR SIDE CLOSING

Sicurezza e resistenza sono alla base del progetto della nuova maniglia Agil, il dispositivo antieffrazione impedisce il movimento del gancio quando la maniglia è chiusa e il gancio regolabile è in acciaio inox garantendo una forte resistenza.

Linee arrotondate e grande adattabilità permettono il fissaggio su lavorazioni rettangolari o rotonde. Ideale per luoghi pubblici e privati risponde agli standard di sicurezza dettate dalle vigenti normative.

La maniglia Agil viene confezionata e fornita con combinazione ritorno manuale, per la combinazione automatica, rimuovere la vite esagonale e inserire la molla in dotazione. Quando la maniglia è chiusa, il dispositivo antieffrazione impedisce il movimento del gancio.

Safety and resistance are the basis of the design of the new Agil handle; the anti-burglary device prevents movement of the hook when the handle is closed and the adjustable hook is made of stainless steel, ensuring strong resistance.

Rounded lines and great adaptability enable assembly on rectangular or round processing.

Ideal for public and private places, it meets the safety standards dictated by regulations in force.

Agil handles are packaged and supplied with manual closing/opening combination. For automatical combination, remove the hexagonal screw from the back side and insert the supplied spring.

When the handle is closed, the anti/burglar device blocks any hook movement.

Agil

ART. 23110.00.00

MANIGLIA AD INCASSO PER CHIUSURE LATERALI
BUILT-IN HANDLES FOR SIDE CLOSING

20 PEZZI / 20 PIECES

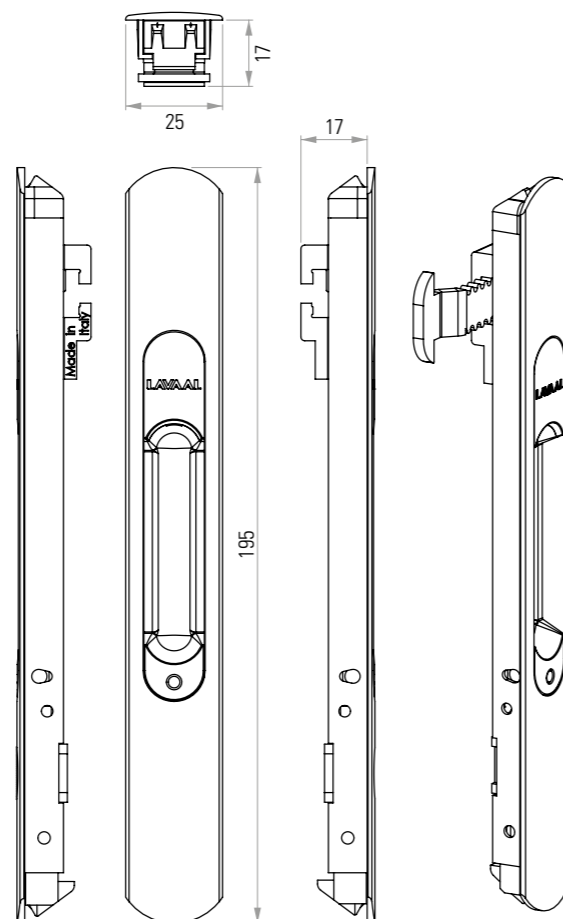

TUTTE LE MANIGLIE SONO STATE COLLAUDATE SECONDO LA NORMATIVA UNI EN 13126-19:2011 OTTENENDO RISULTATI POSITIVI PER DURABILITÀ, RESISTENZA, SICUREZZA E FUNZIONALITÀ.

THE ONLY HANDLES HAVE BEEN TESTED ACCORDING TO UNI EN 13126-19:2011 STANDARDS OBTAINING POSITIVE RESULTS IN DURABILITY, RESISTANCE, SAFETY AND FUNCTIONALITY.

LAVORAZIONE PROFILO QUOTA X VARIABILE
IN FUNZIONE DEL SISTEMA
PROFILE PROCESSING X DIMENSION VARIES
IN RELATION TO THE SYSTEM

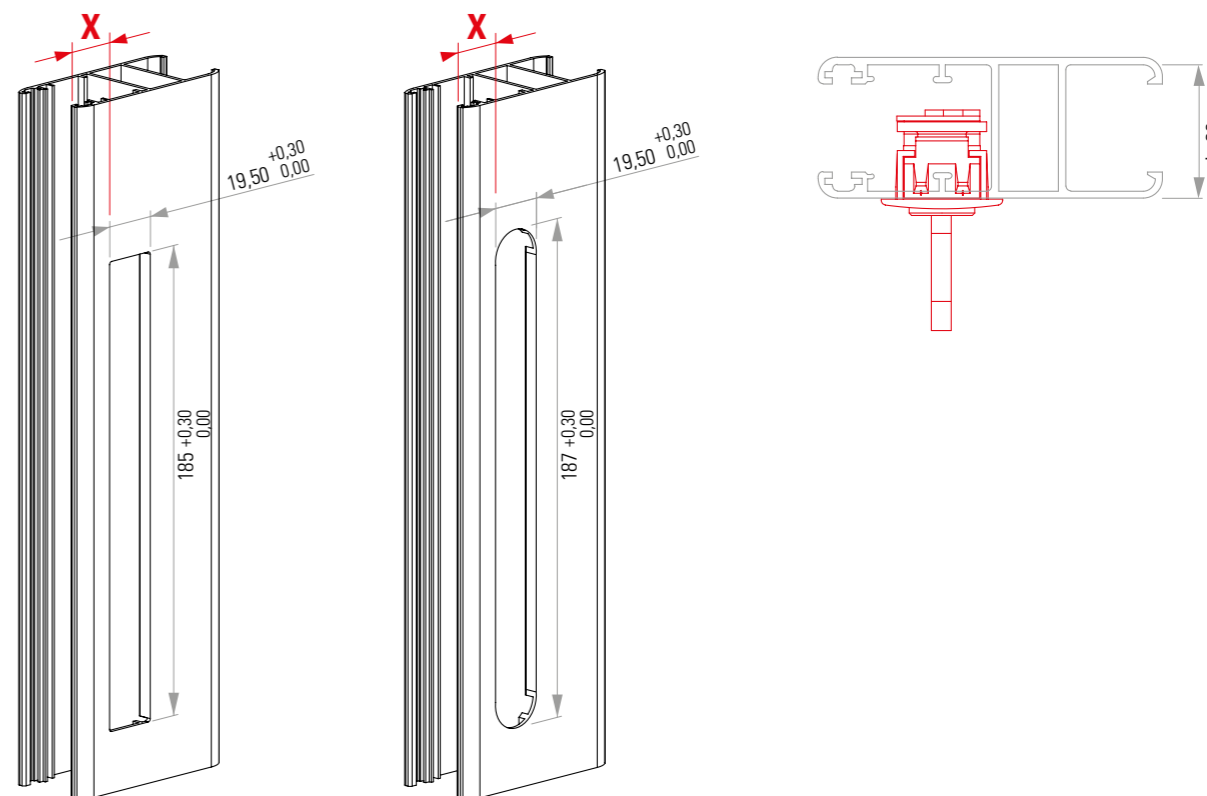

Agil

ART. 23110.00.00
MANIGLIA AD INCASSO PER CHIUSURE LATERALI
 BUILT-IN HANDLES FOR SIDE CLOSING

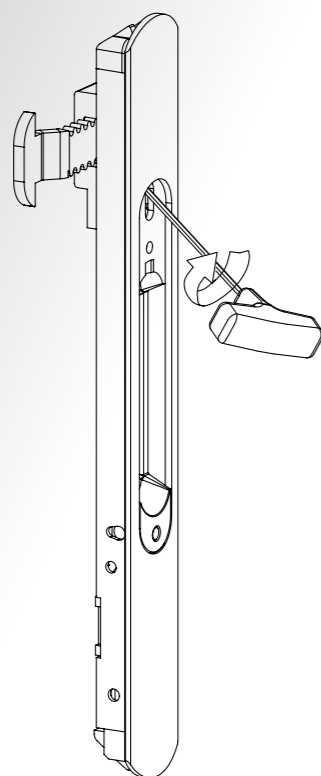
FISSAGGIO DEL GANCIO DI CHIUSURA
 FIXING THE HOOK CLOSURE

SISTEMA DI FISSAGGIO
 FIXING SYSTEM

2 Si fissa al profilo con una leggera pressione.
It can be fixed to the profile with light pressure.

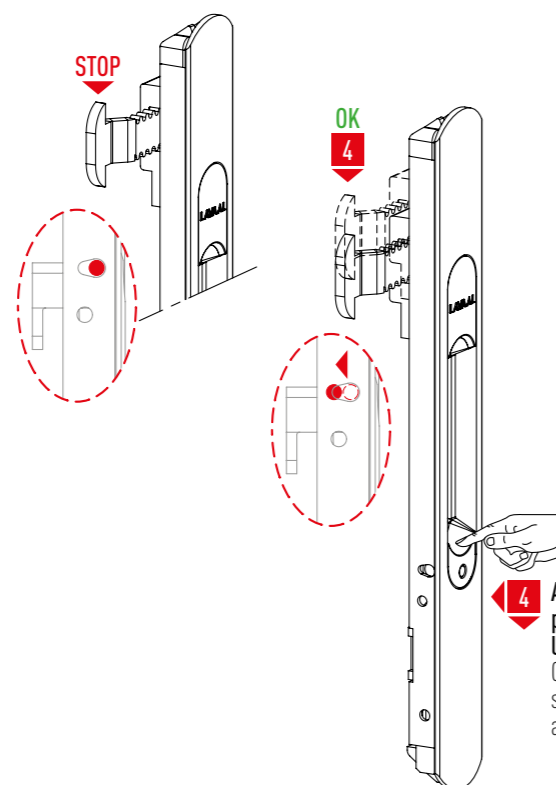
1 Appoggiare al profilo.
Just Put it over the profile.

SISTEMA ANTIEFFRAZIONE
 BURGLAR-PROOF SYSTEM

4 Apertura: con una leggera pressione simultanea verso l'interno e poi in basso.
Opening: with a slight simultaneous pressure inwardly and then the bottom.

SISTEMA DI APERTURA/CHIUSURA

RANGE AGIL CLOSURE SOLUTIONS

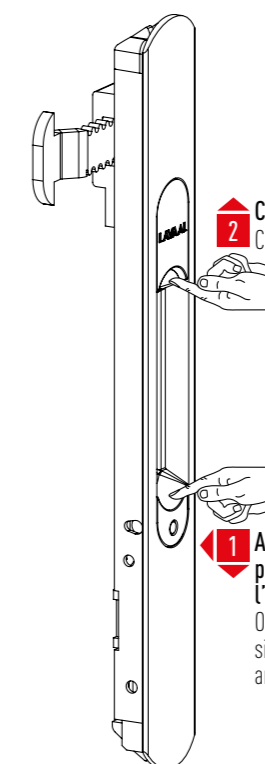
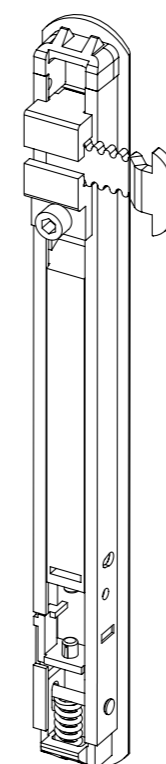
1 **COMBINAZIONE MANUALE**
 MANUAL COMBINATION

2 Chiusura.
Closing.

1 Apertura: con una leggera pressione simultanea verso l'interno e poi in basso.
Opening: with a slight simultaneous pressure inwardly and then the bottom.

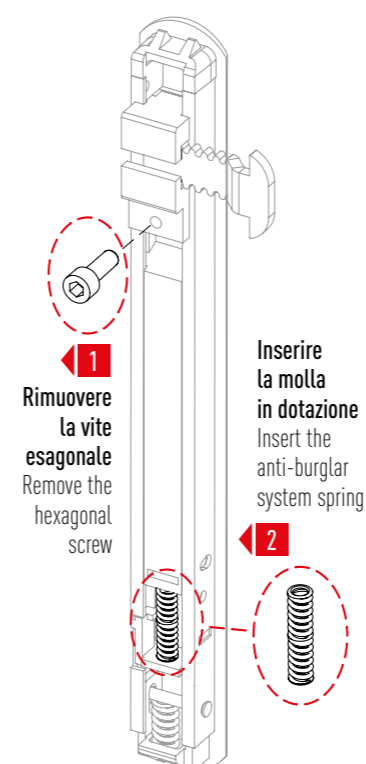
2 **COMBINAZIONE CON RITORNO AUTOMATICO**
 COMBINATION WITH AUTOMATIC RETURN

1 Rimuovere la vite esagonale
Remove the hexagonal screw

Inserire la molla in dotazione
Insert the anti-burglar system spring

2

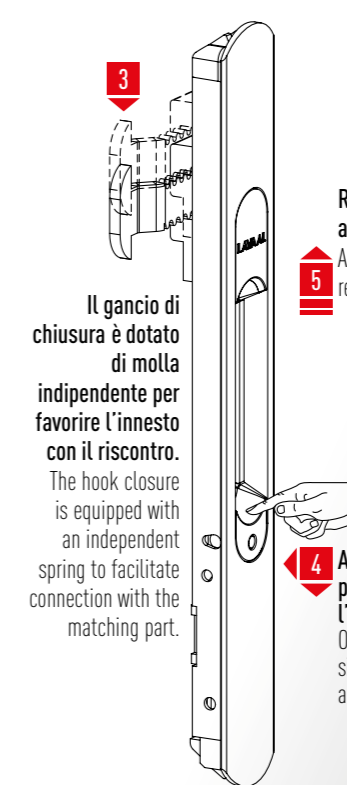

3 Ritorno automatico
Automatic return

Il gancio di chiusura è dotato di molla indipendente per favorire l'innesto con il riscontro.
The hook closure is equipped with an independent spring to facilitate connection with the matching part.

4 Apertura: con una leggera pressione simultanea verso l'interno e poi in basso.
Opening: with a slight simultaneous pressure inwardly and then the bottom.

L'ARTICOLO È MONTATO IN COMBINAZIONE MANUALE, IL KIT COMPRENDE LA MOLLA PER RITORNO AUTOMATICO. VEDI IL PUNTO 2.
IT IS ASSEMBLED WITH THE MANUAL VERSION AND THE SUPPLIED PARTS KIT INCLUDE THE SPRING IF YOU NEED HANDLE TO BE AUTOMATIC RETURN. SEE THE POINT 2.

MANIGLIA AD INCASSO PER CHIUSURE LATERALI.

BUILT-IN HANDLES FOR SIDE CLOSING

AgilKey risponde alla richiesta più diffusa da sempre: la sicurezza degli ambienti in cui si vive. Viene fornita con combinazione manuale e cilindro chiave ad unica cifratura che impedisce l'apertura dell'anta. Tutte le peculiarità della gamma Agil sono conservate nella versione Key, a partire dalle linee arrotondate e alla sua semplicità di montaggio al profilo senza utilizzo di viti.

AgilKey has always satisfied the most common request: safety of our living environment. It is supplied with a manual combination and cylinder key having a unique code, which prevents the panel from opening. All characteristics of the Agil range are maintained in the Key version, from the rounded lines and its easy assembly to the profile without the use of screws.



AgilKey

ART. 23120.00.00

MANIGLIA AD INCASSO PER CHIUSURE LATERALI
BUILT-IN HANDLES FOR SIDE CLOSING

20 PEZZI / 20 PIECES

LAVORAZIONE PROFILO QUOTA X VARIABILE
IN FUNZIONE DEL SISTEMA
PROFILE PROCESSING X DIMENSION VARIES
IN RELATION TO THE SYSTEM

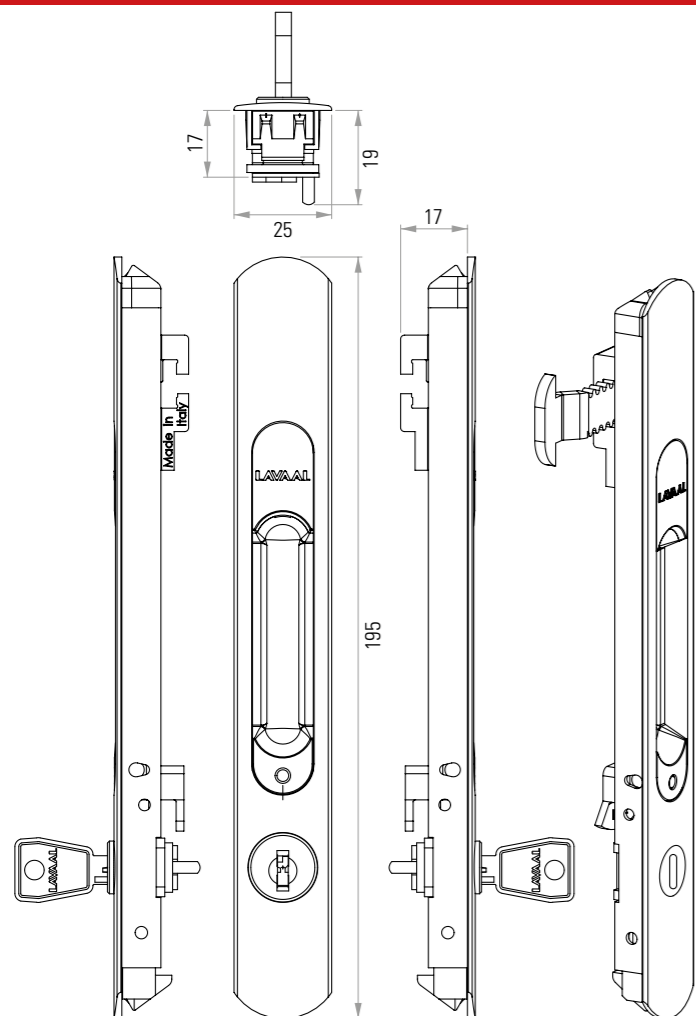
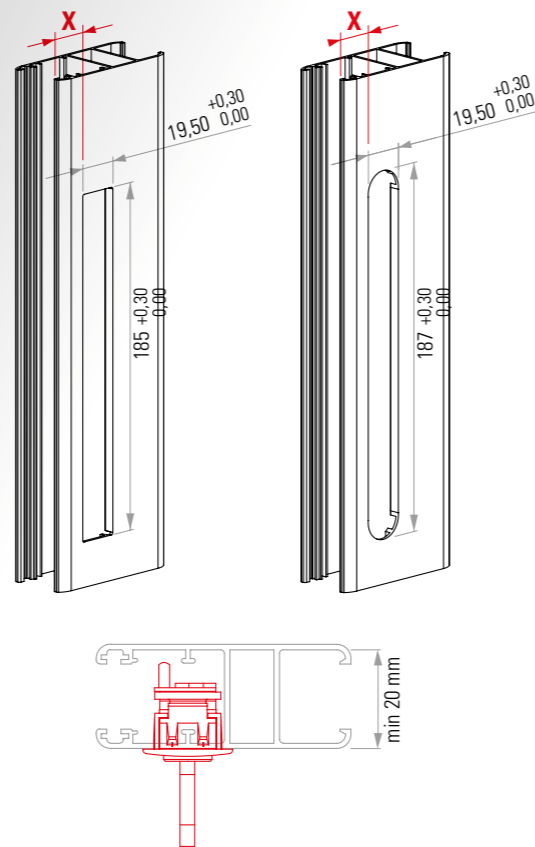

1. Superficie rigata per aumentare la presa.
1. Ribbed surface for better grip.
2. Supporto del gancio rinforzato.
2. Reinforced holder hook

4. Chiavi in dotazione.
4. Keys supplied.

6. Scatto di posizionamento maniglia aperto/chiuso con sistema di antieffrazione.
6. Open/close handle snap positioning with burglar-proof system.

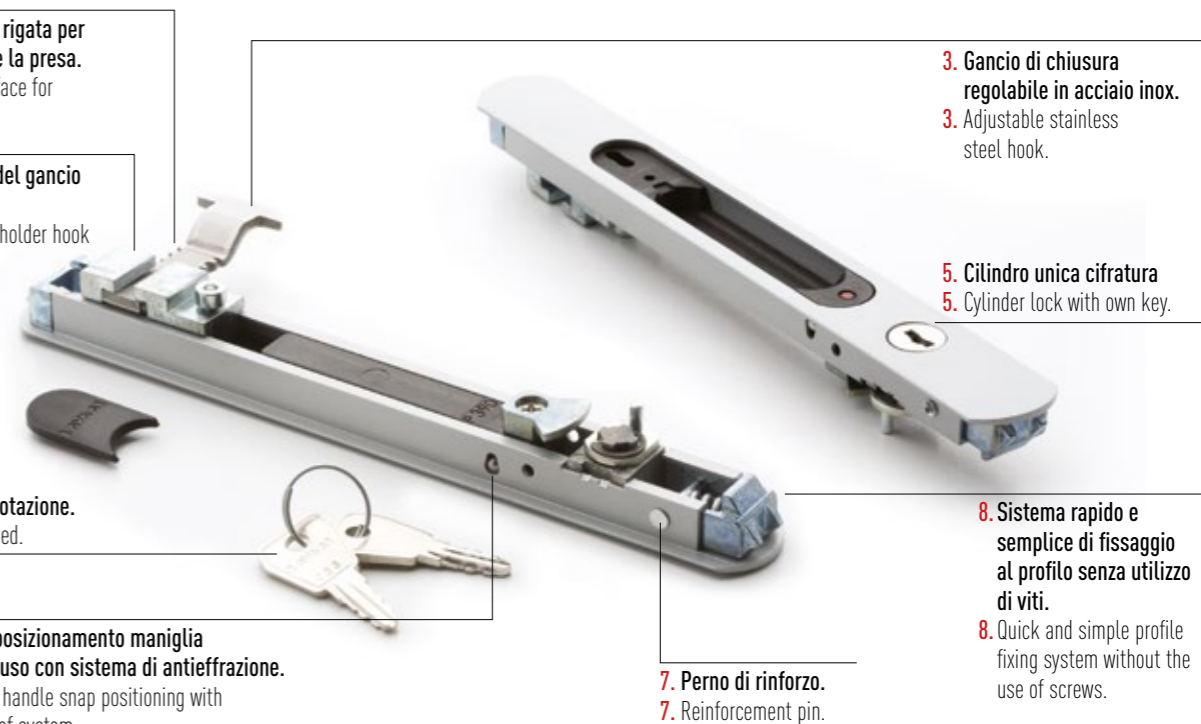

3. Gancio di chiusura regolabile in acciaio inox.
3. Adjustable stainless steel hook.

5. Cilindro unica cifratura
5. Cylinder lock with own key.

8. Sistema rapido e semplice di fissaggio al profilo senza utilizzo di viti.
8. Quick and simple profile fixing system without the use of screws.

7. Perno di rinforzo.
7. Reinforcement pin.

TUTTE LE MANIGLIE SONO STATE COLLAUDATE SECONDO LA NORMATIVA UNI EN 13126-19: 2011 OTTENENDO RISULTATI POSITIVI PER DURABILITÀ, RESISTENZA, SICUREZZA E FUNZIONALITÀ.

THE ONLY HANDLES HAVE BEEN TESTED ACCORDING TO UNI EN 13126-19:2011 STANDARDS OBTAINING POSITIVE RESULTS IN DURABILITY, RESISTANCE, SAFETY AND FUNCTIONALITY.

FISSAGGIO DEL GANCIO DI CHIUSURA
FIXING THE HOOK CLOSURE

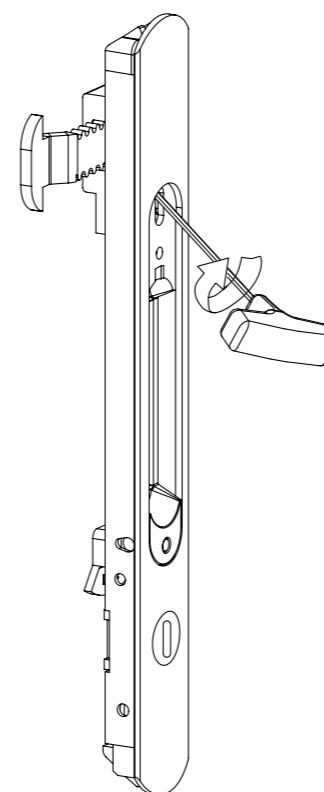

COMBINAZIONE MANUALE
MANUAL COMBINATION

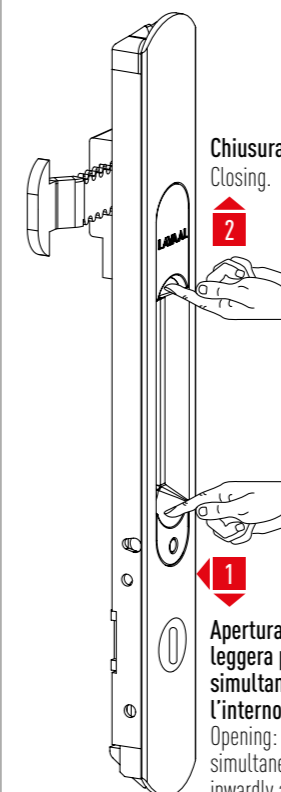

SISTEMA ANTIEFFRAZIONE
BURGLAR-PROOF SYSTEM

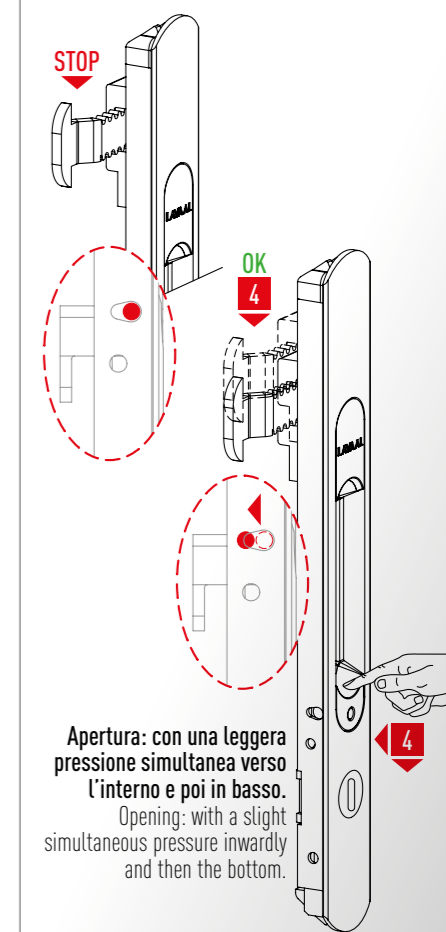

VASCHETTA DI TRASCINAMENTO PER ESTERNO. DUMMY HANDLE FOR THE EXTERNAL SIDE.

Vaschetta di trascinamento ad incasso per chiusure laterali nei serramenti scorrevoli applicabile sulla parte esterna dell'infisso.

AgilTray ha il corpo in alluminio estruso e l'interno in nylon, è reversibile e il suo fissaggio è rapido e sicuro.

Dummy recessed handle for side locks on sliding doors applied on the outside of the frame.

AgilTray body is extruded aluminum made and inner part is nylon made, it is reversible and its assembling in the window is quickly and safely.

ART. 23130.00.00

VASCHETTA DI TRASCINAMENTO PER ESTERNO
DUMMY HANDLE FOR THE EXTERNAL SIDE

20 PEZZI / 20 PIECES

AgilTray

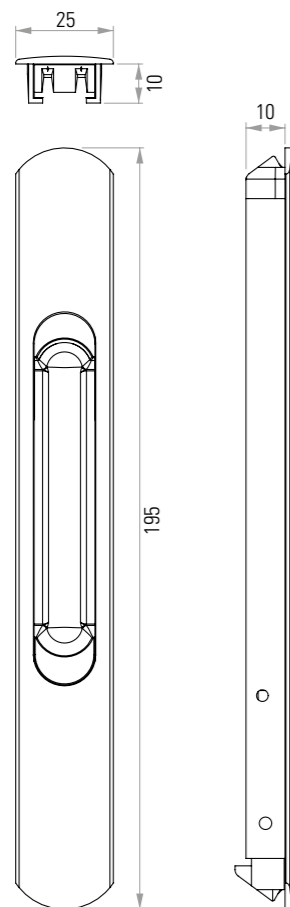

LAVORAZIONE PROFILO QUOTA X VARIABILE
IN FUNZIONE DEL SISTEMA
PROFILE PROCESSING X DIMENSION VARIES
IN RELATION TO THE SYSTEM

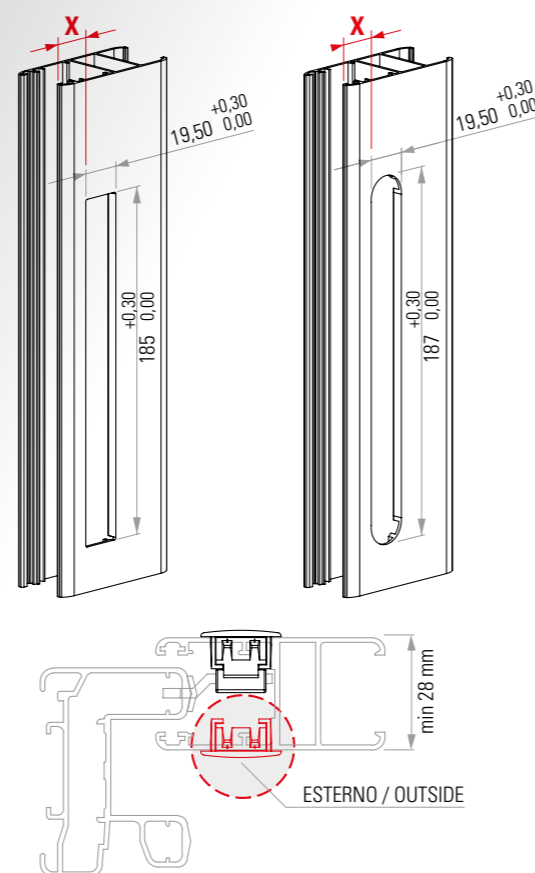

1. Interamente MADE IN ITALY.
1. Entirely MADE IN ITALY.



2. Perno di rinforzo.
2. Reinforcement pin.

3. Sistema rapido e semplice di fissaggio al profilo senza utilizzo di viti.
3. Quick and simple profile fixing system without the use of screws.

TUTTE LE MANIGLIE SONO STATE COLLAUDATE SECONDO LA NORMATIVA
UNI EN 13126-19: 2011 OTTENENDO RISULTATI POSITIVI PER DURABILITÀ, RESISTENZA,
SICUREZZA E FUNZIONALITÀ.

THE ONLY HANDLES HAVE BEEN TESTED ACCORDING TO UNI EN 13126-19:2011 STANDARDS
OBTAINING POSITIVE RESULTS IN DURABILITY, RESISTANCE, SAFETY AND FUNCTIONALITY.

SISTEMA DI FISSAGGIO
FIXING SYSTEM

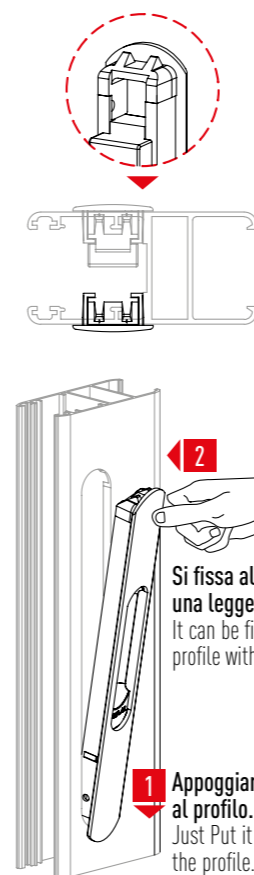

APERTURA SCORREVOLE MANUALE
SLIDING MANUAL



MANIGLIA DI TRASCINAMENTO PER AGIL E AGILKEY.

PULL HANDLE FOR AGIL AND AGILKEY.



Maniglia di trascinamento in alluminio da applicare su porte e finestre scorrevoli. Può essere montata in abbinamento con le maniglie incassate serie AGIL e AGILkey™.

Pull Handle is completely aluminum made and it is applied on doors and sliding windows. It can be mounted connected with the recessed handles series AGIL and AGILkey™.



1. Design coordinato ad AGIL.
1. Coordinated design with Agil.

2. Kit di fissaggio rapido e sicuro.
2. Fixing kit quickly and safely.

3. Sormonto perfetto con Agil.
3. Perfect overlap with the Agil.

AgilPull

ART. 23090.00.00

MANIGLIA DI TRASCINAMENTO PER AGIL E AGILKEY
PULL HANDLE FOR AGIL AND AGILKEY

10 PEZZI / 10 PIECES

TUTTE LE MANIGLIE SONO STATE COLLAUDATE SECONDO LA NORMATIVA UNI EN 13126-19: 2011 OTTENENDO RISULTATI POSITIVI PER DURABILITÀ, RESISTENZA, SICUREZZA E FUNZIONALITÀ.

THE ONLY HANDLES HAVE BEEN TESTED ACCORDING TO UNI EN 13126-19:2011 STANDARDS OBTAINING POSITIVE RESULTS IN DURABILITY, RESISTANCE, SAFETY AND FUNCTIONALITY.

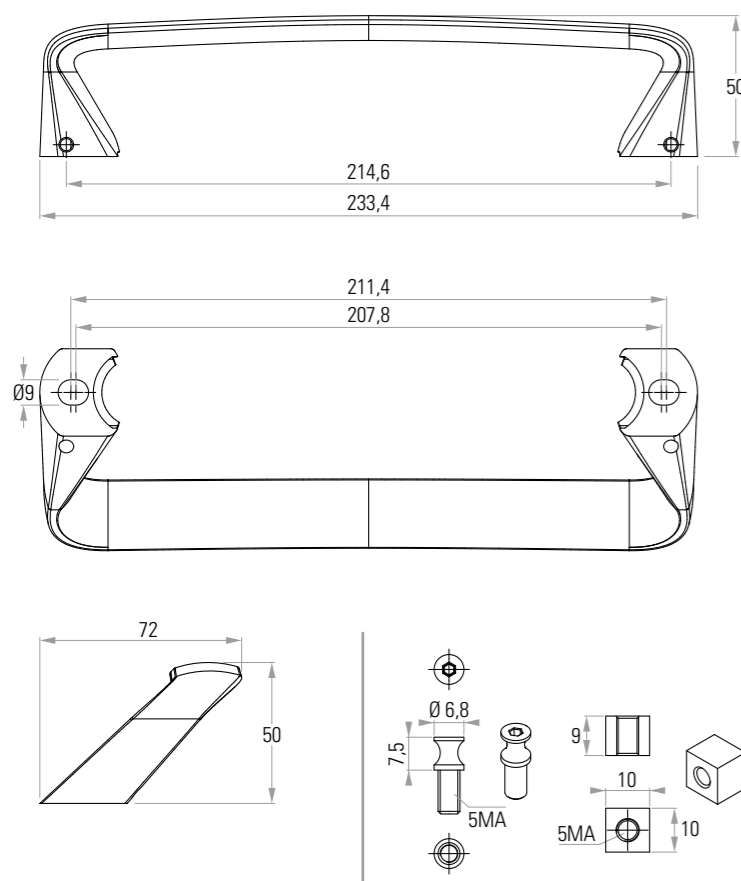

LAVORAZIONE PROFILO QUOTA X VARIABILE
IN FUNZIONE DEL SISTEMA
PROFILE PROCESSING X DIMENSION VARIES
IN RELATION TO THE SYSTEM

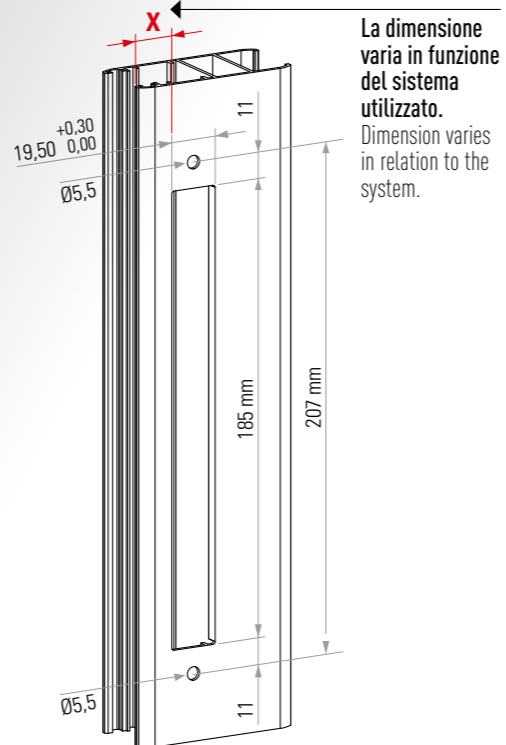

ADATTABILITÀ
ADAPTABILITY

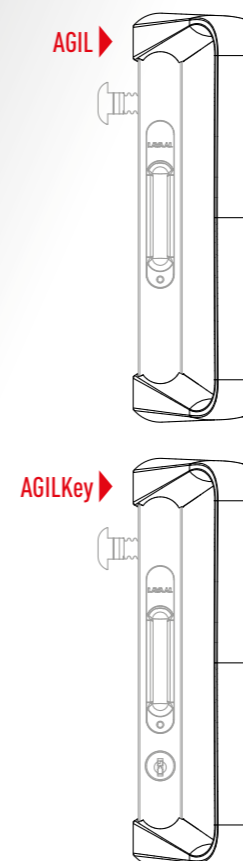

SISTEMA DI FISSAGGIO
FIXING SYSTEM

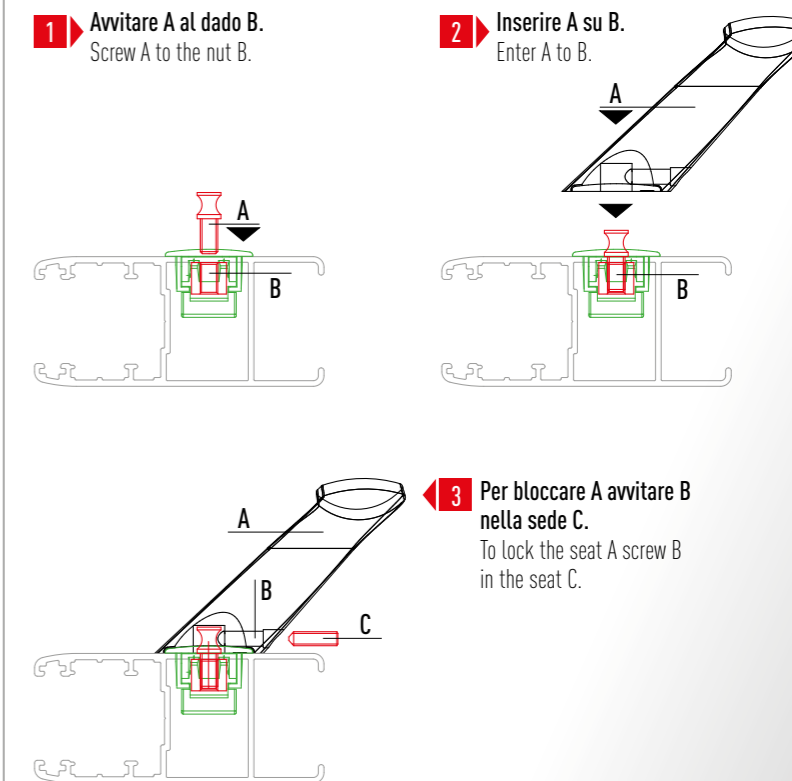

SOLUZIONI DI CHIUSURA GAMMA AGIL

RANGE AGIL CLOSURE SOLUTIONS

01

| ARTICOLO / ARTICLES | L | H | P | S | TYPE | SCATOLA DA / BOX WITH |
|---------------------|------|-----|------|---|------|-----------------------|
| 22170.00.59 | 31 | 7,5 | 8,5 | 3 | 2 | 40 |
| 22180.00.59 | 33 | 4,5 | 9,5 | 3 | 2 | 40 |
| 22200.00.59 | 49 | 5,5 | 11,5 | 3 | 2 | 40 |
| 22440.00.59 | 31 | 3 | 9,5 | 3 | 2 | 40 |
| 22520.00.59 | 28,5 | 1 | 11 | 3 | 2 | 40 |
| 22530.00.59 | 29,5 | - | - | 3 | 1 | 40 |
| 22560.00.59 | 51 | - | - | 3 | 1 | 40 |

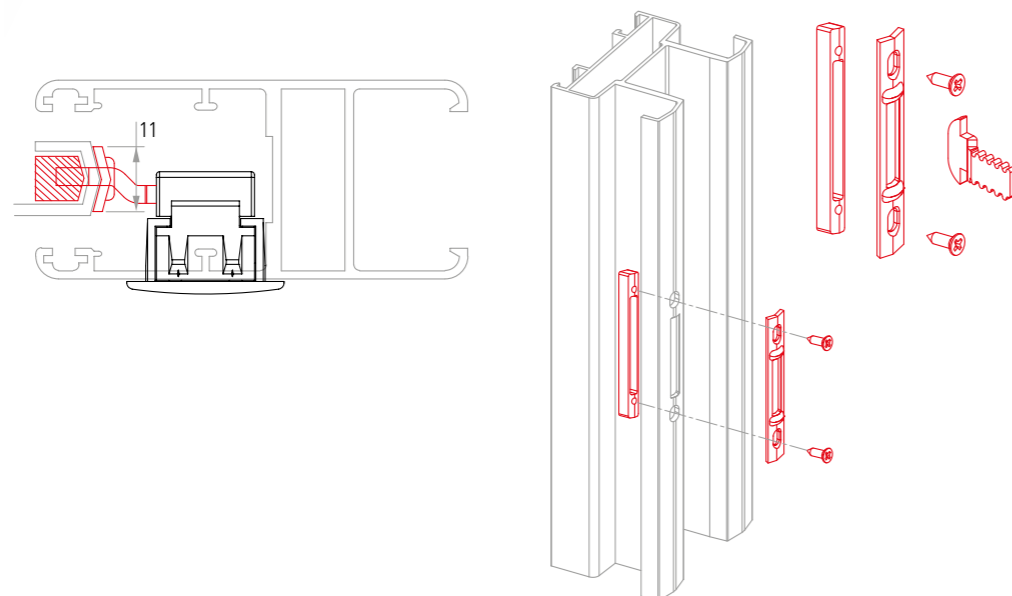
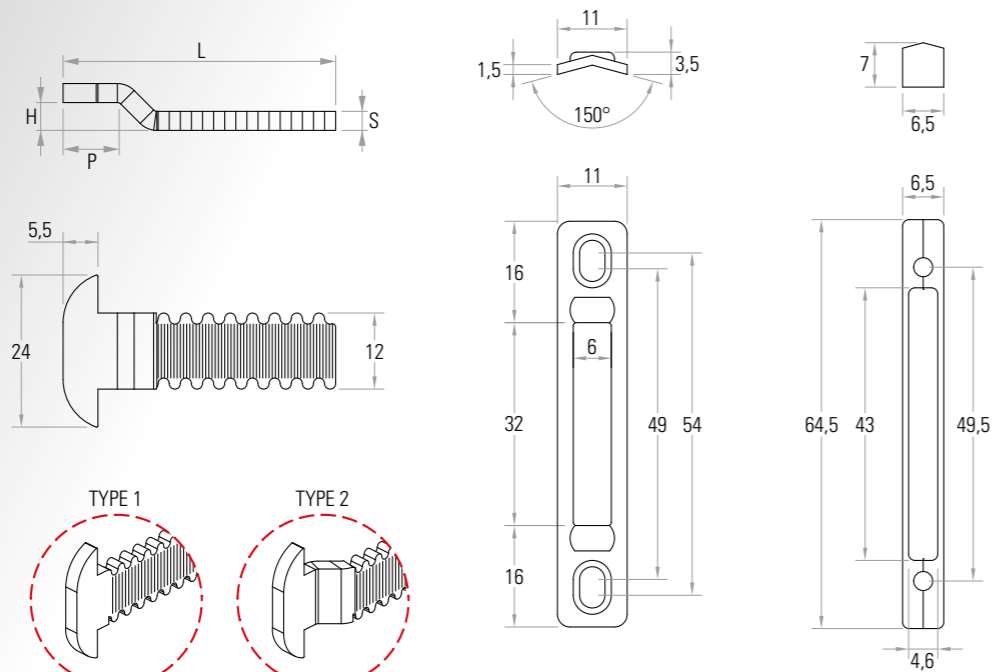

02

| ARTICOLO / ARTICLES | L | H | P | S | TYPE | SCATOLA DA / BOX WITH |
|---------------------|------|-----|------|---|------|-----------------------|
| 22110.00.59 | 33 | 4,5 | 9,5 | 3 | 2 | 40 |
| 22190.00.59 | 29,5 | - | - | 3 | 1 | 40 |
| 22210.00.59 | 49 | 5,5 | 11,5 | 3 | 2 | 40 |
| 22410.00.59 | 31 | 3 | 9,5 | 3 | 2 | 40 |
| 22420.00.59 | 28,5 | 1 | 11 | 3 | 2 | 40 |
| 22430.00.59 | 31 | 7,5 | 8,5 | 3 | 2 | 40 |

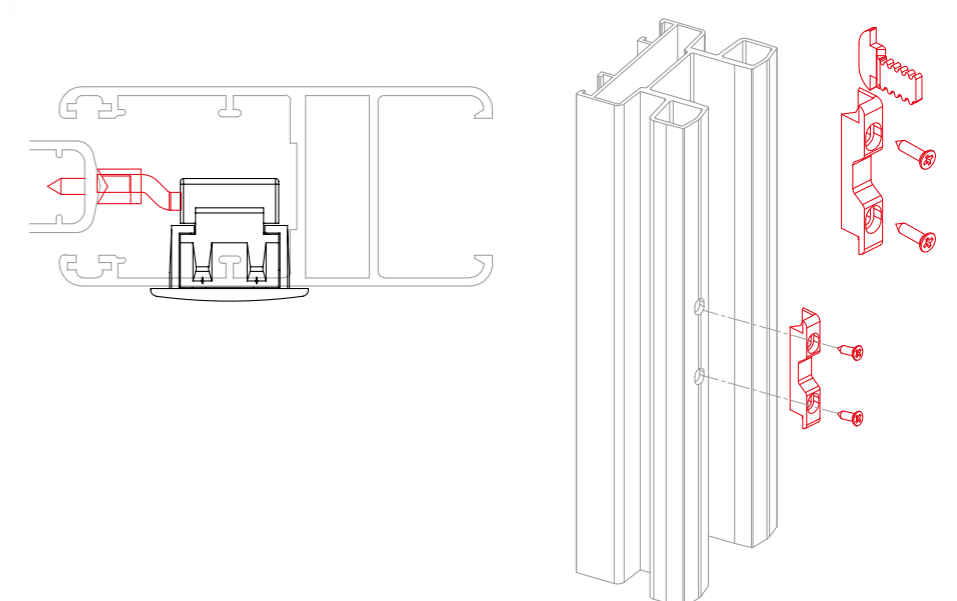
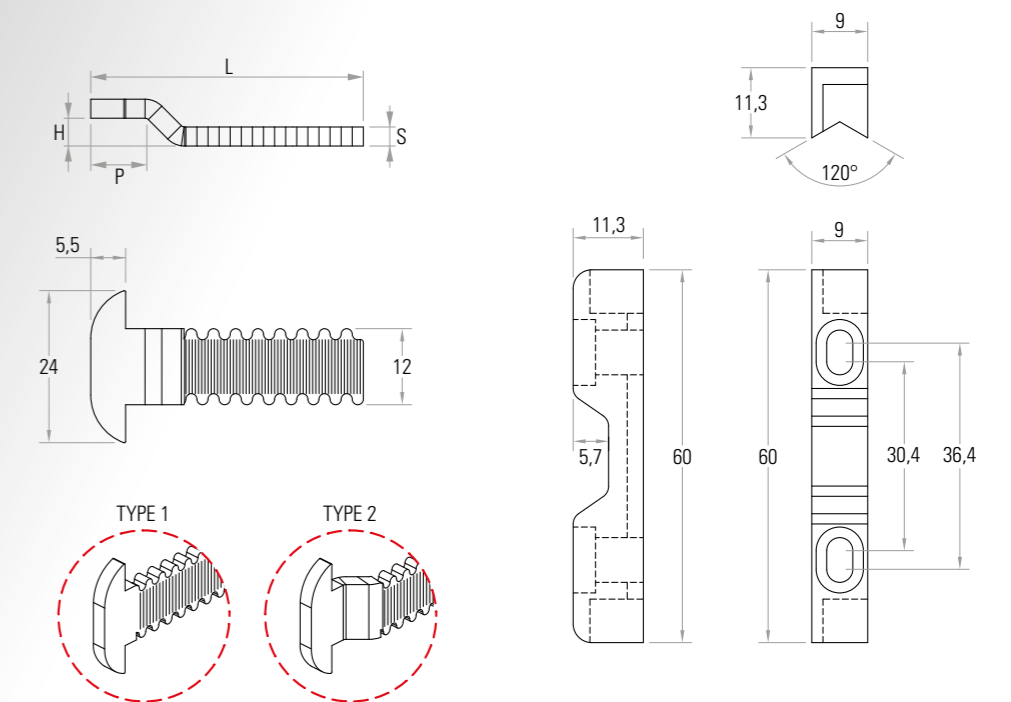

03

| ARTICOLO / ARTICLES | L | H | P | S | TYPE | SCATOLA DA / BOX WITH |
|---------------------|------|-----|------|---|------|-----------------------|
| 22450.00.59 | 29,5 | - | - | 3 | 1 | 40 |
| 22460.00.59 | 28,5 | 1 | 11 | 3 | 2 | 40 |
| 22470.00.59 | 31 | 3 | 9,5 | 3 | 2 | 40 |
| 22480.00.59 | 33 | 4,5 | 9,5 | 3 | 2 | 40 |
| 22540.00.59 | 49 | 5,5 | 11,5 | 3 | 2 | 40 |
| 22550.00.59 | 31 | 7,5 | 8,5 | 3 | 2 | 40 |

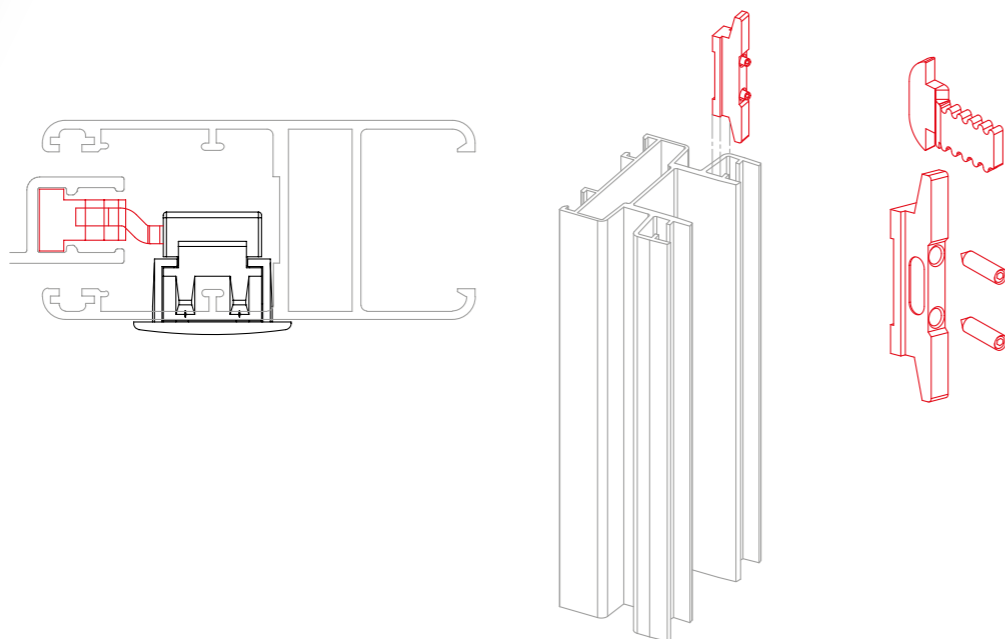
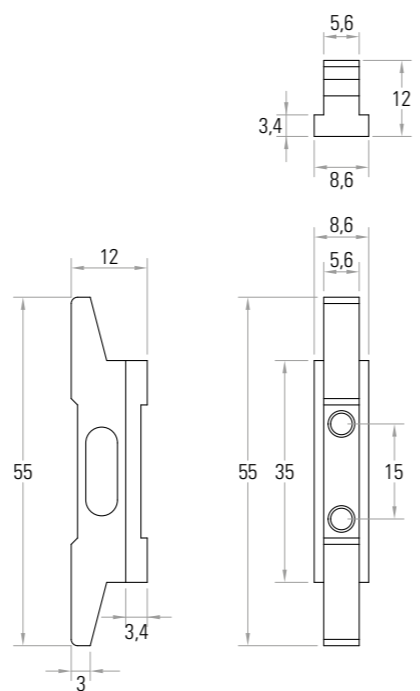
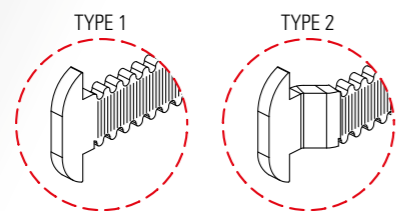
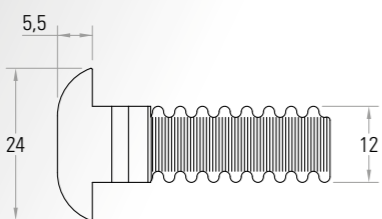
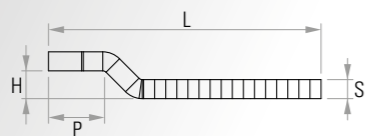

04

| ARTICOLO / ARTICLES | L | H | P | S | TYPE | SCATOLA DA / BOX WITH |
|---------------------|----|-----|------|---|------|-----------------------|
| 22100.00.59 | 33 | 4,5 | 9,5 | 3 | 2 | 40 |
| 22120.00.59 | 49 | 5,5 | 11,5 | 3 | 2 | 40 |
| 22140.00.59 | 31 | 3 | 9,5 | 3 | 2 | 40 |
| 22400.00.59 | 31 | 7,5 | 8,5 | 3 | 2 | 40 |

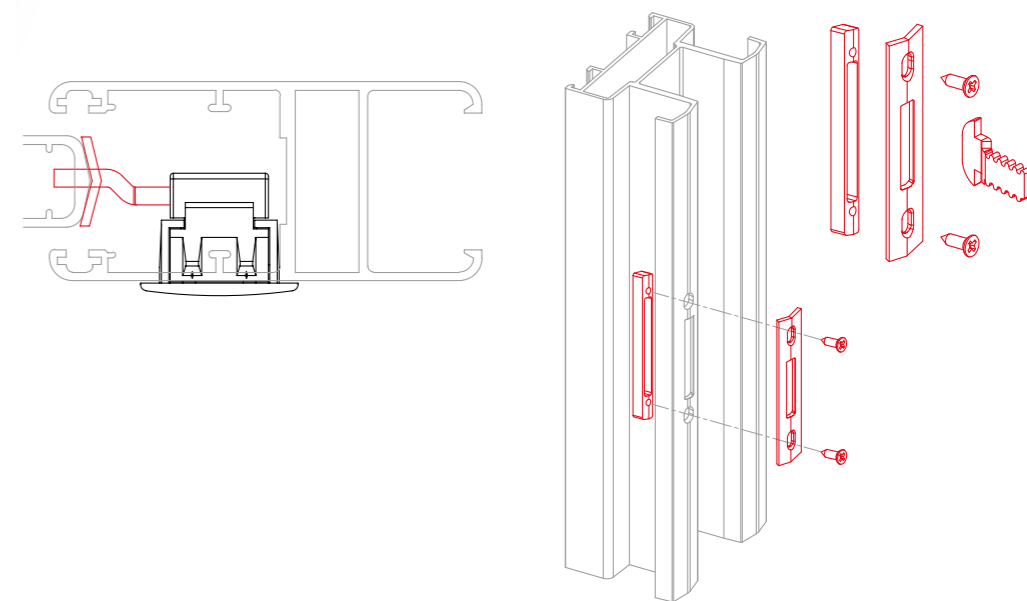
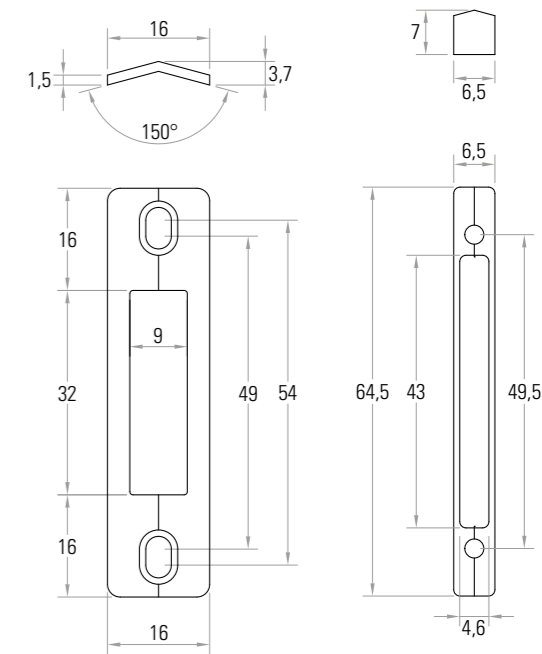
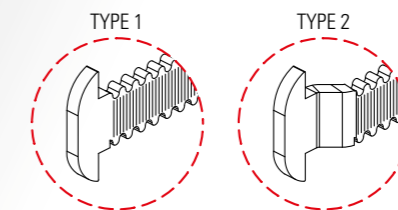
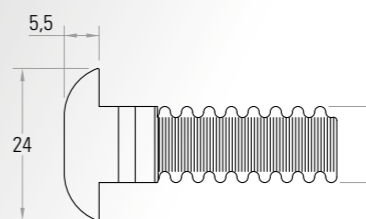
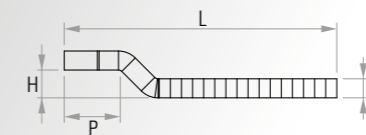

05

| ARTICOLO / ARTICLES | L | H | P | S | TYPE | SCATOLA DA / BOX WITH |
|---------------------|------|-----|-----|---|------|-----------------------|
| 22500.00.59 | 33 | 4,5 | 9,5 | 3 | 2 | 40 |
| 22510.00.59 | 28,5 | 1 | 11 | 3 | 2 | 40 |

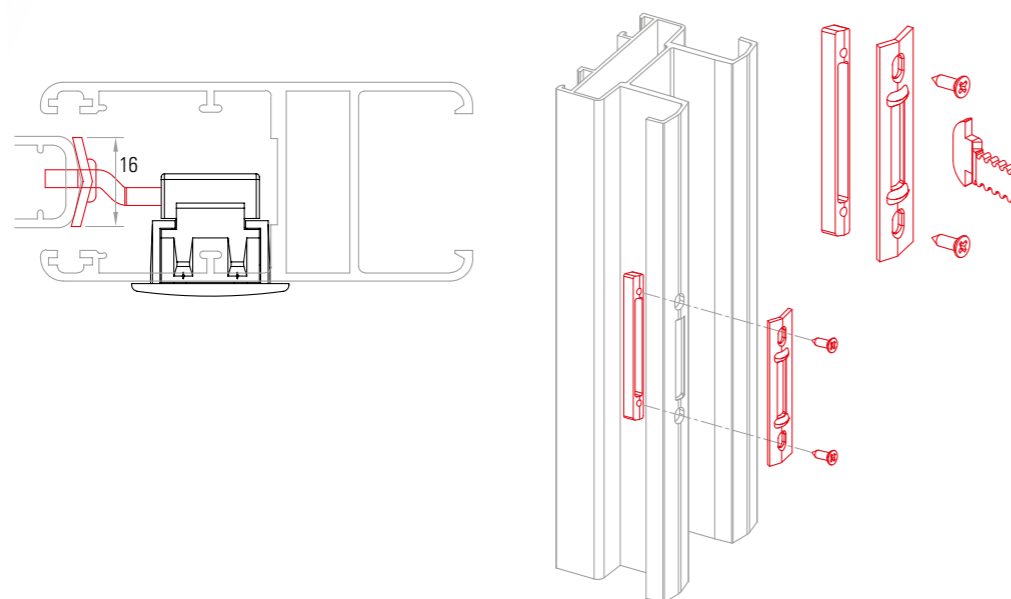
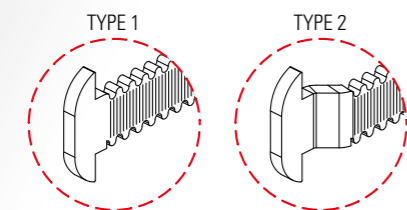
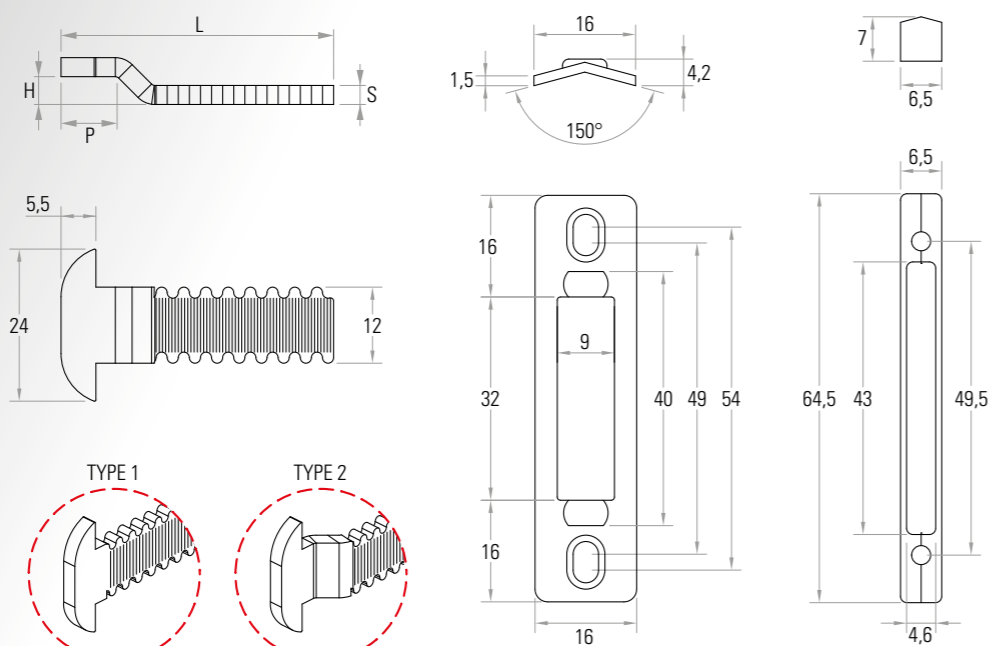

ACCESSORI ACCESSORIES

ART. 22960.00.59

RISCONTRO IN ACCIAIO INOX
STAINLESS STEEL STRIKER

200 PEZZI / 200 PIECES

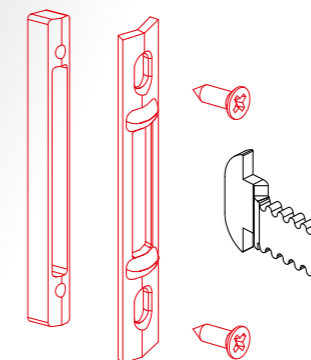
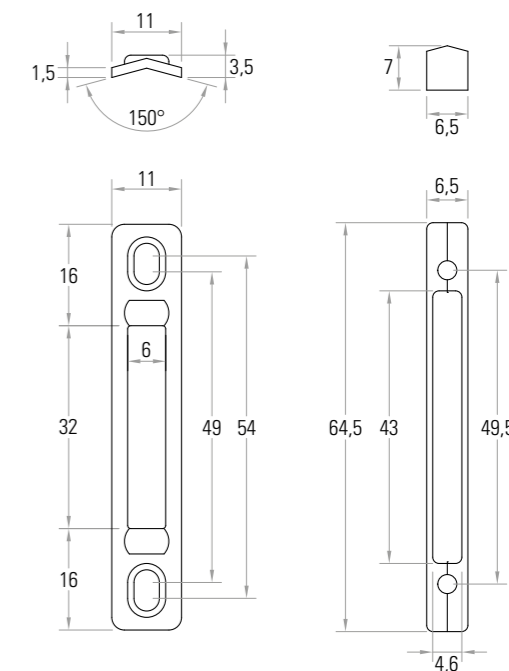

ART. 22970.00.59

GANCIO IN ACCIAIO INOX
STAINLESS STEEL HOOK

200 PEZZI / 200 PIECES

| ARTICOLO / ARTICLES | L | H | P | S | TYPE |
|---------------------|------|-----|------|---|------|
| 22970.00.59 | 29,5 | - | - | 3 | 1 |
| 22980.00.59 | 49 | - | - | 3 | 1 |
| 22990.00.59 | 28,5 | 1 | 11 | 3 | 2 |
| 23260.00.59 | 31 | 3 | 9,5 | 3 | 2 |
| 23270.00.59 | 33 | 4,5 | 9,5 | 3 | 2 |
| 23280.00.59 | 49 | 5,5 | 11,5 | 3 | 2 |
| 23290.00.59 | 31 | 7,5 | 8,5 | 3 | 2 |
| 23870.00.59 | 29 | 2 | 7,5 | 3 | 2 |
| 23880.00.59 | 41 | 2 | 10 | 3 | 2 |
| 23890.00.59 | 43 | 4,5 | 9,5 | 3 | 2 |

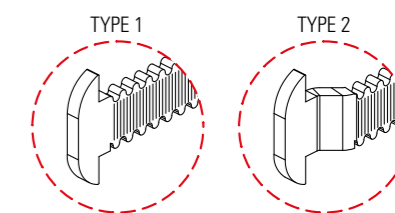
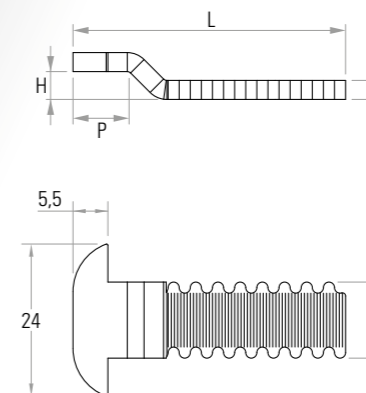

ACCESSORI ACCESSORIES



ART. 09970.00.00

RISCONTRO AD APPLICAZIONE ESTERNA
STRIKER TO EXTERNAL APPLICATION

200 PEZZI / 200 PIECES

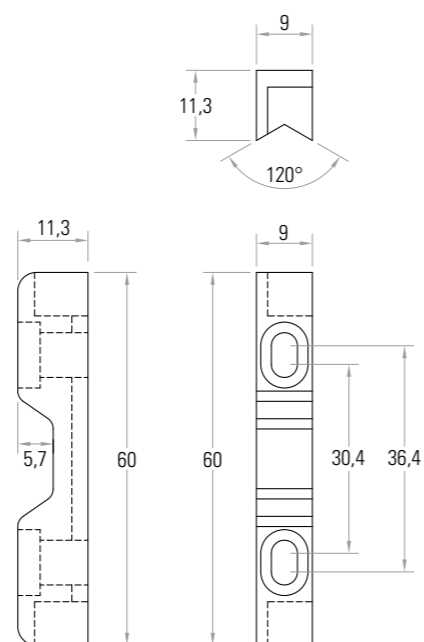
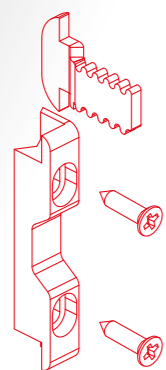

ART. 21750.00.00

RISCONTRO PER BINARI APERTI
STRIKER FOR OPEN ROD SYSTEM

200 PEZZI / 200 PIECES

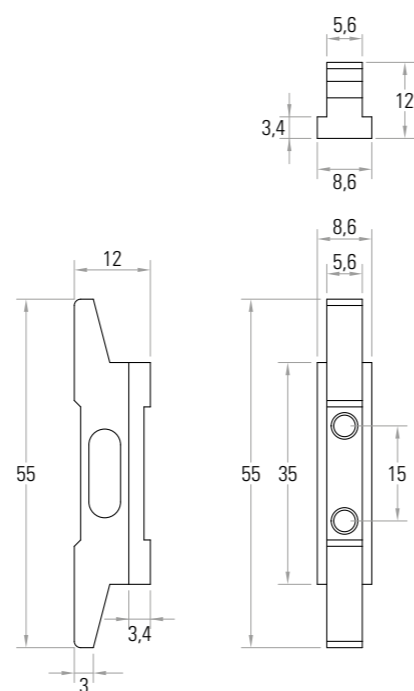
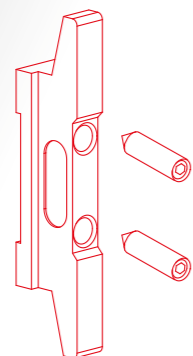

ART. 23990.00.00

RISCONTRO PER BINARI APERTI
STRIKER FOR OPEN ROD SYSTEM

200 PEZZI / 200 PIECES

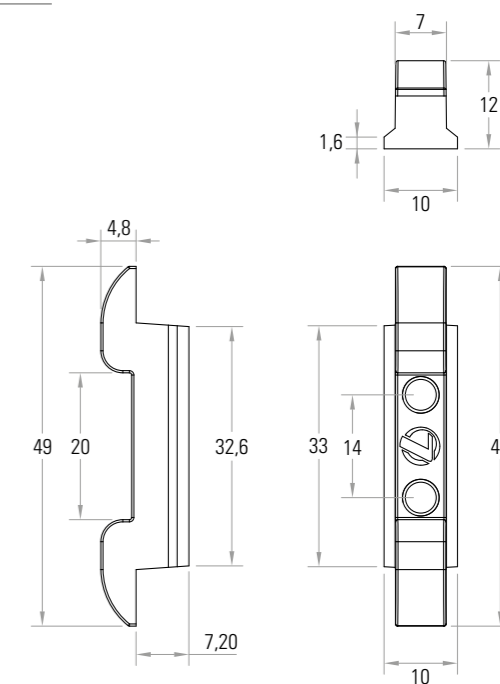
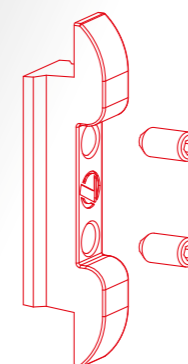

LAVAAL INTERNATIONAL srl

VIA DEL PROGRESSO S.N.
64023 MOSCIANO S.A. (TE)
TEL. +39.085.807921
FAX. +39.085.8071578

info@lavaal.com
www.lavaal.com

